

DETAIL "C"

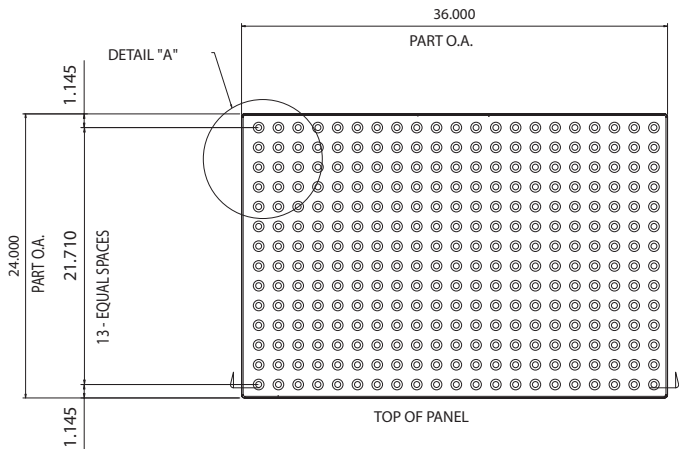

TOP OF PANEL

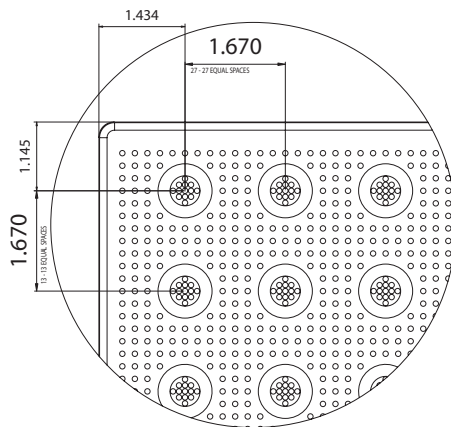

DETAIL "A"

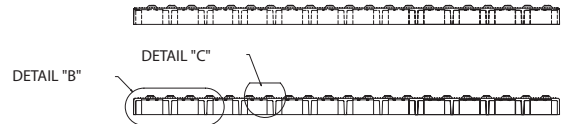

DETAIL "B"

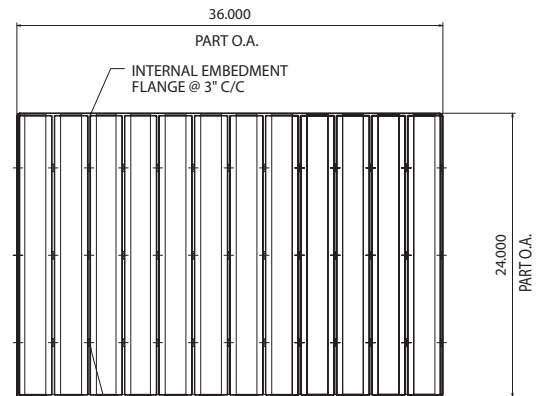

INTERNAL EMBEDMENT FLANGE @ 3" C/C
BOTTOM OF PANEL
0.625" DIA. HOLE EMBEDMENT FLANGES

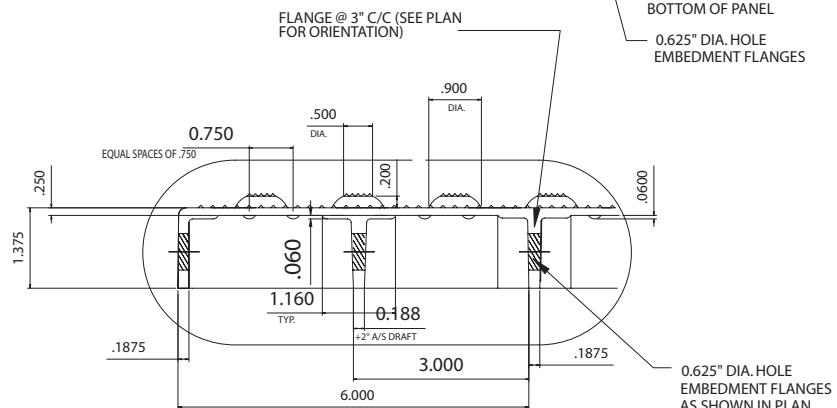

DETAIL "B"

MATERIAL LIST			
ITEM	DESCRIPTION	PART NO.	QTY
1			
2			
3			
4			
SCALE		AS NOTED FULL SIZE	
TRADE		PART NO.	
DETECTABLE WARNING SURFACE		SEE MATERIAL LIST	
MATERIAL			
PROJECT			
EMBEDMENT PANEL DETECTABLE WARNING SURFACE SYSTEM 24" x 36" SOUND ATTENUATING CURB RAMP TILE (INLINE DOME) PLANS AND DETAILS			
DRAWING NO.		REV. NO.	
ADA SOLUTIONS, INC. PO BOX 3 N.BILLERICA, MA 01862			